





***ENGLISH***

**CP-180  
INSTRUCTION MANUAL**

# CONTENTS

1. INSTALLING THE CONTROL PANEL .....	1
2. CONNECTING THE CORD.....	1
3. CONFIGURATION .....	2
4. SETTING PROCEDURE OF THE MACHINE HEAD.....	2
5. ADJUSTING THE MACHINE HEAD(direct-drive motor type sewing machine only)...	3
6. EXPLANATION OF THE CONTROL PANREL.....	4
7. HOW TO OPERATE THE CONTROL PANEL FOR SEWING STITCHING PATTERNS...	5
8. ONE-TOUCH SETTING .....	9
9. PRODUCTION SUPPORT FUNCTION .....	9
10. HOW TO USE THE BOBBIN THREAD COUNTER .....	12
11. HOW TO USE THE THREAD TRIMMING COUNTER .....	13
12. NEEDLE UP/DOWN COMPENSATION SWITCH .....	13
13. KEY LOCK FUNCTION .....	14
14. ON/OFF SWITCH  OF THE MATERIAL EDGE SENSOR .....	14
15. AUTOMATIC THREAD TRIMMING SWITCH  .....	14
16. ONE-SHOT AUTOMATIC STITCHING SWITCH  .....	14
17. THREAD TRIMMING PROHIBITION SWITCH  .....	15
18. FUNCTION SETTING SWITCH .....	15
19. OPTIONAL INPUT/OUTPUT SETTINGS .....	16
20. AUTOMATIC COMPENSATION OF NEUTRAL POINT OF THE PEDAL SENSOR...	18
21. SETTING OF THE AUTO LIFTER FUNCTION.....	18
22. INITIALIZATION OF THE SETTING DATA.....	19
23. CHECKING PROCEDURE OF THE ERROR CODE.....	19

**WARNING :**

This Instruction Manual is for the control panel, CP-180.

Read "Safety Instructions" of the Instruction Manual for the control box carefully beforehand and understand them before using CP-180.

In addition, be careful not to splash water or oil on it, or shock such as dropping and the like since this product is a precision instrument.

## 1. INSTALLING THE CONTROL PANEL

**WARNING :**

To prevent personal injury caused by abrupt start of the sewing machine, carry out the work after turning OFF the power switch and ascertaining that the motor has completely stopped.

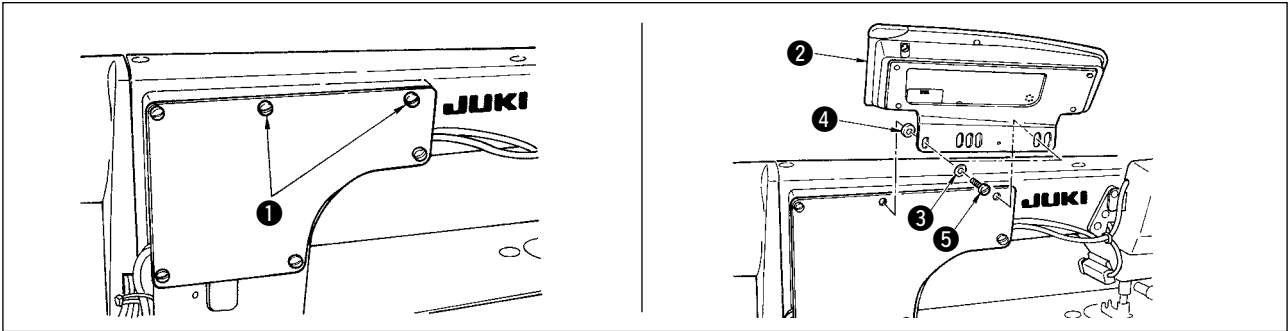

- 1) Remove side plate setscrews ① from the side plate.
- 2) Install control panel ② on the machine head using screws ⑤, flat washers ③ and rubber seat ④ supplied with the control panel as the accessories.



1. DDL-9000B (Not provided with AK) is given as an example of installing procedure.

2. Screw to install the panel changes according to the machine head used. Refer to Table 1 and confirm the kind of screw.

< The relation between the respective machine heads and the positions of installing hole of the bracket are as described in the table. >

Table 1

	Installing hole	Screw	
DDL-9000A	① - ⑤	M5 X 12	Screw supplied with panel as accessories
DDL-9000B	① - ⑤	(Provided with AK) M5 X 14	Side plate setscrew
		(Not provided with AK) M5 X 12	Screw supplied with panel as accessories
LH-3500A	② - ⑤	M5 X 14	Side plate setscrew

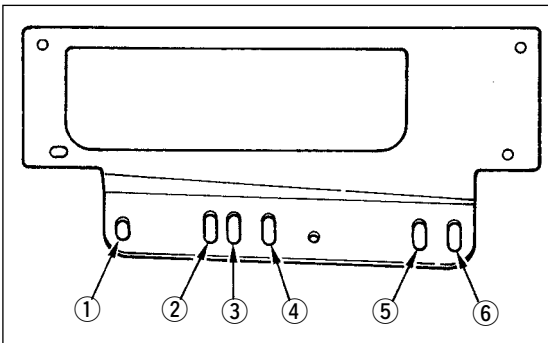

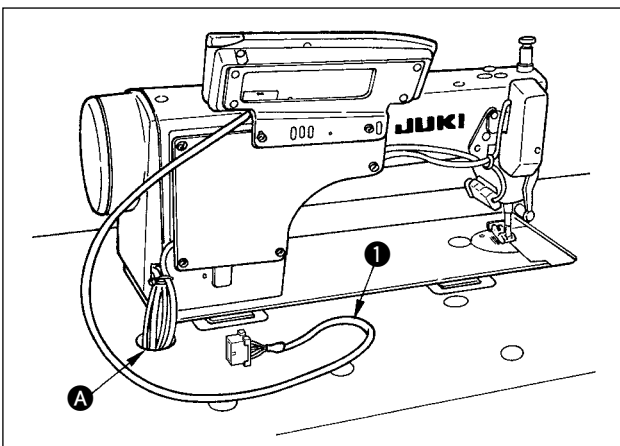

## 2. CONNECTING THE CORD

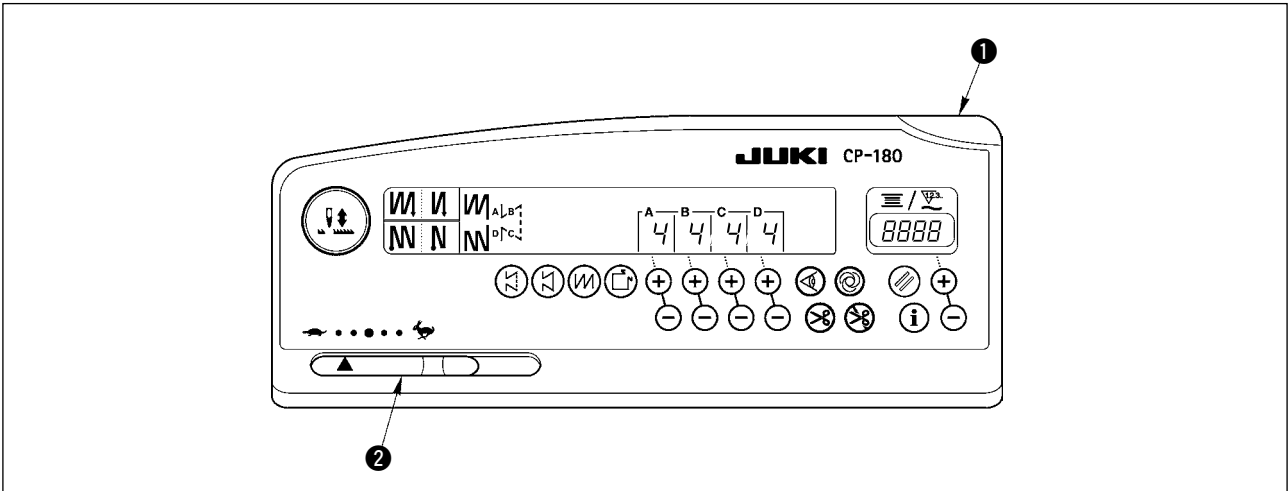

- 1) Pass cord ① of the control panel through hole A in the machine table route it to the underside of the table.
- 2) As for the connection of the connector, refer to the Instruction Manual for the control box.

### 3. CONFIGURATION



- ① Power indicator lamp (LED) : Lights up when the power switch is turned ON.
- ② Max. speed limitation variable resistor : Limits the speed when it is moved to the left (  ).

### 4. SETTING PROCEDURE OF THE MACHINE HEAD

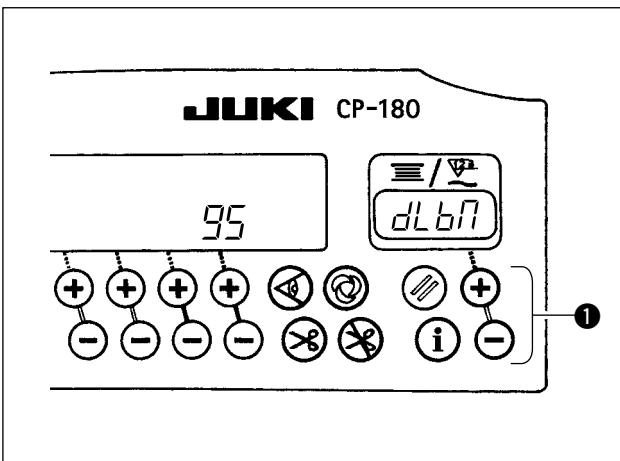

- 1) Refer to "18. FUNCTION SETTING SWITCH" p.15, and call the function setting No. 95.
  - 2) The type of machine head can be selected by pressing switch ①.
- \* Refer to "CAUTIONS WHEN SETTING UP THE SEWING MACHINE" or "Machine head list" on the separate sheet for the types of machine heads.

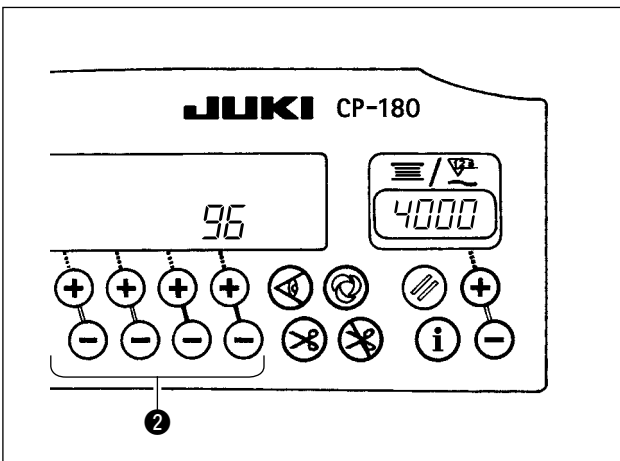

- 3) After selecting the type of machine head, by pressing switch ②, the step proceeds to 96 or 94, and the display automatically initializes to the contents of the setting corresponding with the type of machine head.

## 5. ADJUSTING THE MACHINE HEAD (DIRECT-DRIVE MOTOR TYPE SEWING MACHINE ONLY)



### WARNING :

Be sure to perform the angle adjustment of the machine head by the operation below before using the machine head.

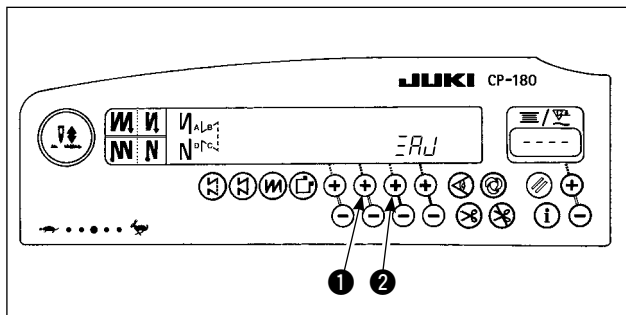

- 1) Simultaneously pressing switch ① and switch ②, turn ON the power switch.

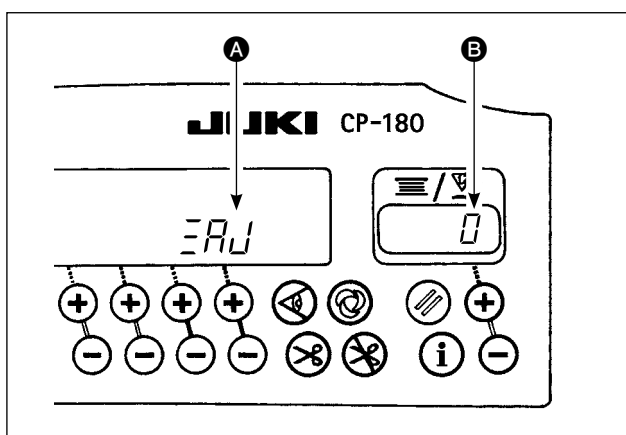

- 2) ERR is displayed A in the indicator and the mode is changed over to the adjustment mode.
- 3) Turn the handwheel by hand and angle B is displayed in the indicator when the reference signal has been detected.  
(The value is the reference value.)

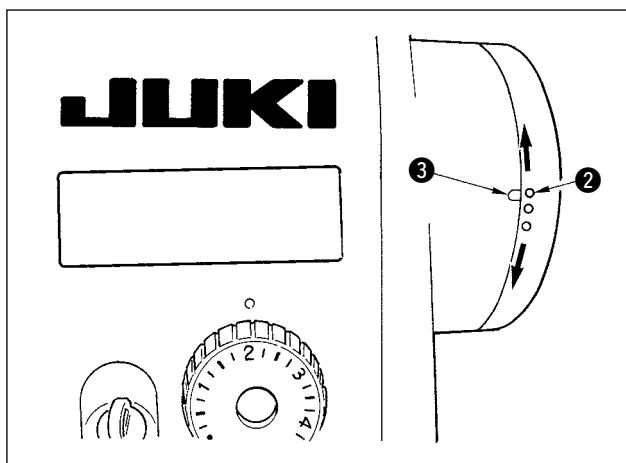

- 4) In this state, align the white dot ② of the handwheel with the concave ③ of the handwheel cover as shown in the figure.

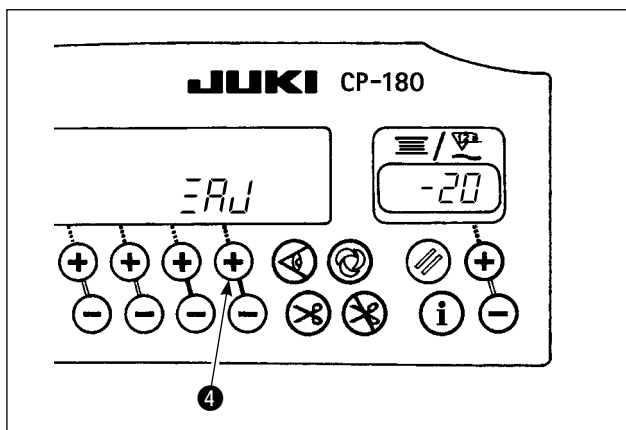

- 5) Press switch ④ to finish the adjustment work.  
(The value is the reference value.)

## 6. EXPLANATION OF THE CONTROL PANEL

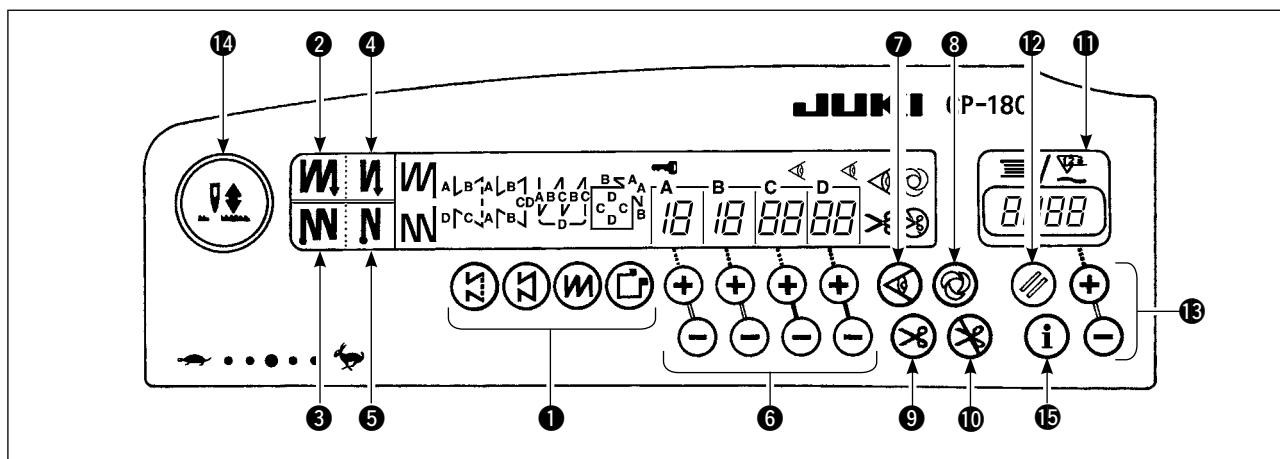

<b>1</b>	<b>Pattern selector switch</b> • Used for selecting a pattern from among the four different patterns.
<b>2</b>	<b>Double reverse stitching (for start) switch</b> • Used for turning ON/OFF the double reverse stitching for start.
<b>3</b>	<b>Double reverse stitching (for end) switch</b> • Used for turning ON/OFF the double reverse stitching for end.
<b>4</b>	<b>Automatic reverse stitching (for start) switch</b> • Used for turning ON/OFF the automatic reverse stitching for start.
<b>5</b>	<b>Automatic reverse stitching (for end) switch</b> • Used for turning ON/OFF the automatic reverse stitching for end.
<b>6</b>	<b>Switches for setting the number of stitches</b> • Used for setting the number of stitches to be sewn in processes A through D.
<b>7</b>	<b>Material edge sensor ON/OFF switch</b> • Rendered effective when the material edge sensor is installed on the machine. • Used for setting whether or not the material edge sensor is used during sewing.
<b>8</b>	<b>One-shot automatic stitching switch</b> • Rendered effective when the material edge sensor is installed on the machine or when the sewing machine is operated under the constant-dimension stitching mode. • Start the sewing machine with this switch, and the sewing machine will run automatically until the material edge is detected or the end of a constant-dimension stitching is reached.
<b>9</b>	<b>Automatic thread trimming switch</b> • Rendered effective when the material edge sensor is installed on the machine or when the sewing machine is operated under the constant-dimension stitching mode. • Even keep depressing the front part of the pedal, the sensor can detect the material edge, or after the completion of the constant-dimension stitching mode, the machine will automatically perform thread trimming.

<b>10</b>	<b>Thread trimming prohibition switch</b> • Used for prohibiting thread trimming at any occasion.
<b>11</b>	<b>Bobbin thread counter/thread trimming counter</b> • Bobbin thread counter/thread trimming counter can be changed over by the function of the control box main body. <b>Bobbin thread counter :</b> • Indicates the amount of bobbin thread while counting it by subtracting from the set value. • When the bobbin thread remaining amount detecting device is installed on the machine, the counter indicates the number of times of detecting. <b>Thread trimming counter :</b> • Every time thread trimming is performed, the counter value is added.
<b>12</b>	<b>Bobbin counter reset switch</b> • Used for returning the value shown on the bobbin thread counter to the initial value. • When the thread trimming counter is selected, it is reset to [0].
<b>13</b>	<b>Bobbin thread amount setting switch</b> • Used for setting the amount of bobbin thread.
<b>14</b>	<b>Needle up/down compensation switch</b> • Used for performing needle up/down compensation stitching. <b>[Changeover selection of needle bar stop position when the pedal is in its neutral position]</b> • Pressing the needle up/down compensation switch, turn ON the power to the machine, and the needle bar stop position when the pedal is in its neutral position is changed over to down position/up position. • Confirmation of the stop position can be performed at the front cover of the control box. When up position stop is specified : " nP UP " When down stop position is specified : " nP Lo "
<b>15</b>	<b>Information switch</b> • Used for calling the production support function and calling the one-touch setting (by keeping the switch held pressed for one second.)

# 7. HOW TO OPERATE THE CONTROL PANEL FOR SEWING STITCHING PATTERNS

## (1) Reverse stitching pattern

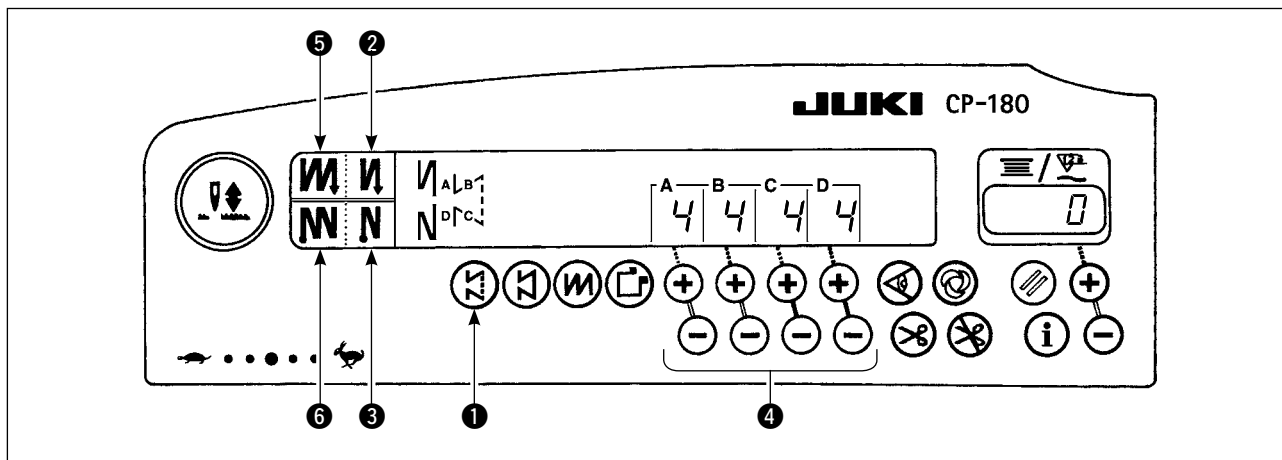

②	OFF	ON	OFF	ON
Sewing pattern				
③	OFF	OFF	ON	ON

- 1) Press reverse stitching pattern switch ① to specify the reverse stitching pattern.
- 2) The reverse stitching pattern is selected, and the number of stitches and data on reverse stitching which have already been specified are shown on the panel.
- 3) If you want to change the number of stitches, operate the "+" or "-" switch of switches ④ for setting the number of stitches A through D.  
 (The range of the number of stitches that can be changed : 0 to 19 stitches)
- 4) Four different stitching patterns can be performed by matching the ON and OFF settings of automatic reverse stitching (for start) switch ② and automatic reverse stitching (for end) switch ③.
- 5) Furthermore, the double reverse stitching can be selected by operating the double reverse stitching (for start) switch ⑤ and double reverse stitching (for end) switch ⑥.

**(2) Constant-dimension stitching pattern**

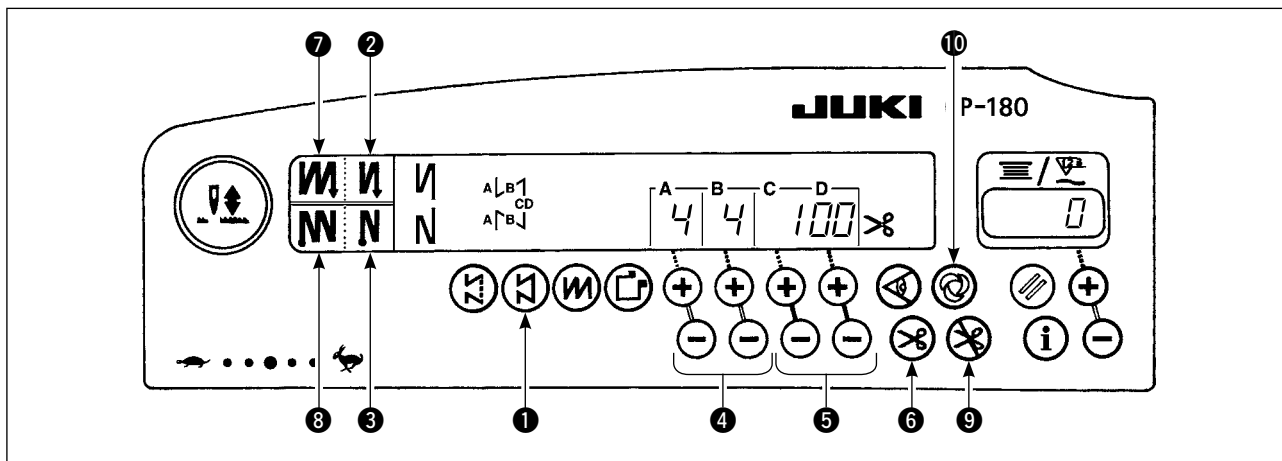

<b>2</b>	OFF	ON	OFF	ON
Sewing pattern				
<b>3</b>	OFF	OFF	ON	ON

- 1) Press constant-dimension stitching pattern switch **1** on the control panel to select the constant-dimension stitching pattern.
- 2) The constant-dimension stitching pattern is selected. Now, the predetermined number of stitches and the state of reverse stitching function are shown on the control panel.
- 3) To change the number of stitches of the processes in the constant-dimension stitching pattern, change the number of stitches for processes C and D by operating switches **5** for setting the number of stitches for processes C and D. Select the reverse feed stitching accordingly. To change the number of reverse-feed stitches, operate switches **4** for setting the number of stitches for processes A and B.

( Adjusting range : A, B = to 19 stitches  
C, D = 5 to 500 stitches )

- 4) Four different kinds of stitching patterns can be performed according to the combination of ON/OFF settings of automatic reverse stitching (for start) switch **2** and automatic reverse stitching (for end) switch **3**.
- 5) Furthermore, the double reverse stitching mode can be specified by operating double reverse stitching (for start) switch **7** and double reverse stitching (for end) switch **8**.
- 6) If automatic thread trimming switch **6** is turned ON, the sewing machine will automatically perform thread trimming after it finishes the predetermined number of stitches between C and D. (If the automatic reverse feed stitching (for end) is selected, the sewing machine will automatically perform thread trimming after it finishes the automatic reverse stitching (for end) even when the automatic thread trimming switch is not selected.)  
If automatic thread trimming switch **6** is turned OFF, operate the touch-back switch after the completion of processes C and D. Then the machine runs at a low speed (stitch compensation operation). Also, if the pedal is returned to its neutral position and depressed its front part again, the sewing can be continued regardless of the setting of number of stitches.
- 7) If thread trimming prohibiting function **9** is chosen, the machine will stop with the needle up without performing thread trimming.
- 8) If one-shot automatic stitching function **10** is chosen, the machine will automatically perform sewing at a stretch, at the specified speed by depressing the front part of the pedal.



### (3) Overlapped stitching pattern

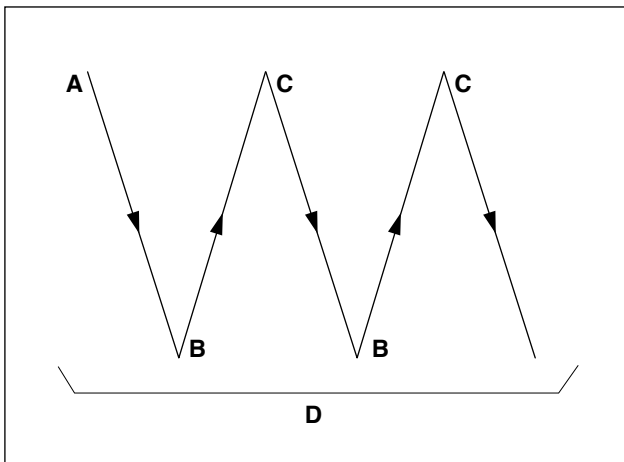
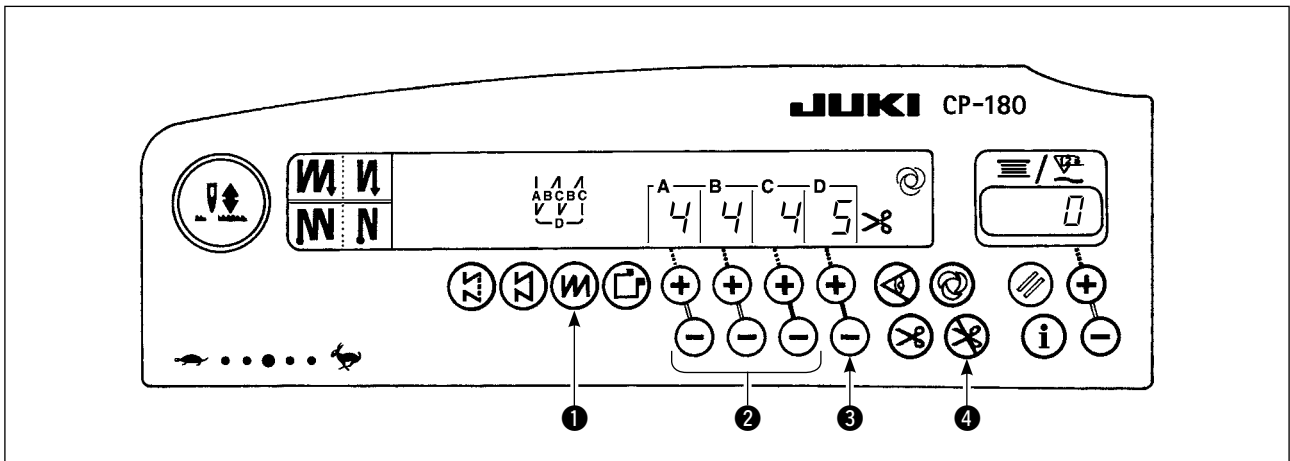

- 1) Press overlapped stitching pattern switch **1** to specify the overlapped stitching pattern.
- 2) The overlapped stitching pattern is selected, and the number of stitches and data on overlapped stitching which have already been specified are shown on the panel.
- 3) If you want to change the number of stitches, operate number of stitches setting switches **2** for processes A through C, and to change the number of repeated processes, operate the "+" or "-" switch of switch **3** for setting the number of processes D.

( The range of the number of stitches A, B and C that can be changed : 0 to 19 stitches.  
The range of the number of processes D that can be changed : 0 to 9 times. )

- 4) Depress the front part of the pedal once, and the sewing machine will repeat the normal stitching and reverse stitching by the predetermined times. Then, the sewing machine will automatically make the thread trimmer actuate and will stop to complete the overlapped stitching procedure. (The one-shot automatic stitching cannot be turned OFF.)
- 5) If thread trimming prohibiting function **4** is chosen, the machine will stop with the needle up upon completion of the overlapped stitching procedure without performing thread trimming.

#### (4) Rectangular stitching pattern

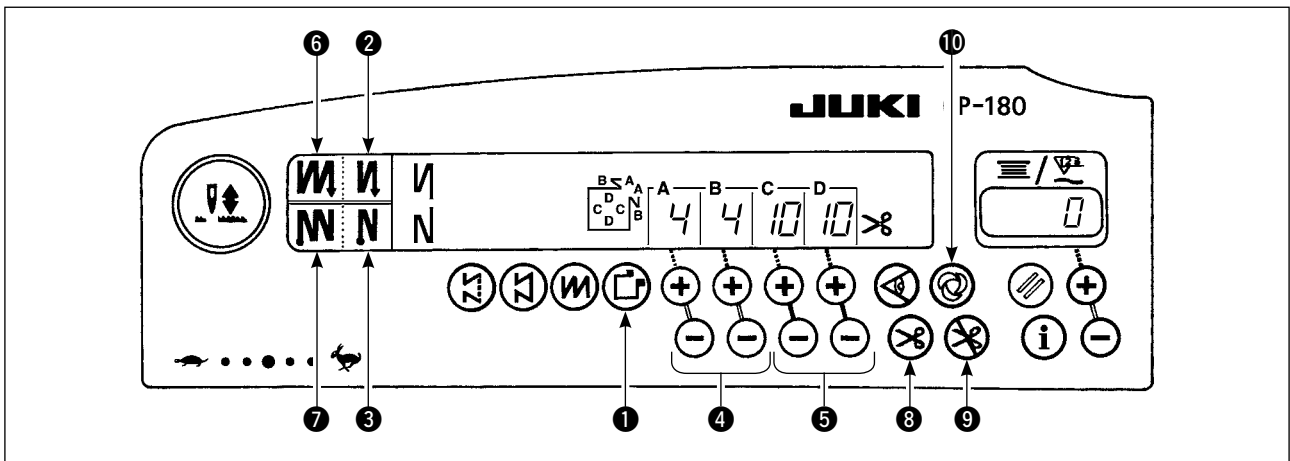

	OFF	ON	OFF	ON
Sewing pattern				
	OFF	OFF	ON	ON

- 1) Press rectangular stitching pattern switch **1** on the control panel to select the rectangular stitching pattern.
- 2) The rectangular stitching pattern is selected. Now, the predetermined number of stitches and other sewing data are shown on the control panel.
- 3) To change the number of stitches of the processes in the rectangular stitching pattern, operate switches **5** (for processes C and D) to change the number of stitches for processes C and D. Select the reverse feed stitching accordingly. To change the number of reverse-feed stitches, operate switches **4** for setting the number of stitches for processes A and B.

(Adjustable range : A, B = 0 to 19 stitches, C, D = 0 to 99 stitches)

- 4) Four different kinds of stitching patterns can be performed according to the combination of ON/OFF settings of automatic reverse stitching (for start) switch **2** and automatic reverse stitching (for end) switch **3**.
- 5) Furthermore, the double reverse stitching mode can be specified by operating double reverse stitching (for start) switch **6** and double reverse stitching (for end) switch **7**.  
At each step the sewing machine automatically stops after sewing the predetermined number of stitches. At this time, if the touch-back switch is operated, the sewing machine runs at a low speed (stitch compensation operation). Also, at the last process, if the pedal is returned to its neutral position and depressed its front part again, the sewing can be continued regardless of the setting of number of stitches.
- 6) If automatic thread trimming switch **8** is turned ON, the sewing machine will automatically perform thread trimming after the completion of the last process. (If the automatic reverse stitching (for end) is selected, the sewing machine will automatically perform thread trimming after it finishes the automatic reverse stitching (for end).)
- 7) If thread trimming prohibiting function **9** is chosen, the machine will stop with the needle up without performing thread trimming.
- 8) If one-shot automatic stitching function **10** is chosen, the machine will automatically perform sewing at a stretch until the number of stitches specified is reached, at the predetermined sewing speed by depressing the pedal while the sewing machine is engaged in the sewing of process C or D. The machine performs thread trimming in the last process of one-shot automatic stitching pattern.
- 9) For the sewing machine equipped with an auto-lifter, the presser foot will automatically go up after the completion of each sewing process.

## 8. ONE-TOUCH SETTING

A part of function setting items can be easily changed in the normal sewing state.



### WARNING :

For the setting of functions other than those covered in this part, refer to "Instruction manual for the SC-920".

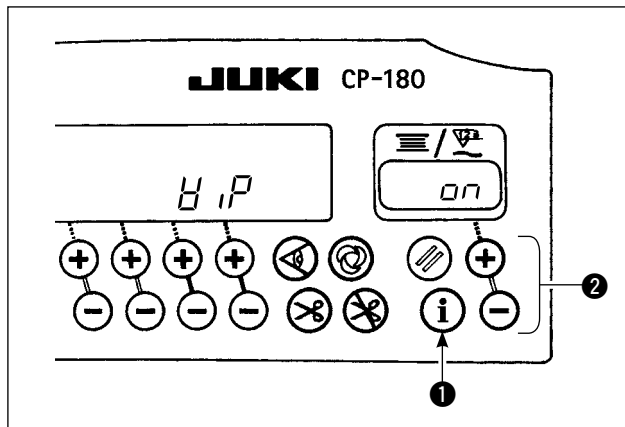

### < One-touch setting procedure >

- 1) Keep switch ❶ held pressed one second to enter the function setting mode.
- 2) The set value can be changed by using switch ❷.
- 3) To return to the normal sewing state, press switch ❶.



The setting is confirmed by pressing switch ❶.

\* Wiper function ( *H P* )

□FF : Wiper does not operate after thread trimming

□n : Wiper operates after thread trimming

## 9. PRODUCTION SUPPORT FUNCTION

The production support function consists of two different functions (five different modes) such as the production volume management function, operation measuring function. Each of them has its own production support effect. Select the appropriate function (mode) as required.

### < Production volume management function >

- Target No. of pcs. display mode [F100]
- Target/actual No. of pcs difference display mode [F200]

The target number of pieces, actual number of pieces and the difference between the target and actual number of pieces along with the operation time are displayed to notify the operators of a delay and advance in real time. Sewing machine operators are allowed to engage sewing while constantly checking his/her work pace. This helps raise target awareness, thereby increasing productivity. In addition, a delay in work can be found at an early stage to enable early detection of problems and early implementation of corrective measures.

### < Operation measuring function >

- Sewing machine availability rate display mode [F300]
- Pitch time display mode [F400]
- Average number of revolutions display mode [F500]

Sewing machine availability status is automatically measured and displayed on the control panel. The data obtained can be used as basic data to perform process analyses, line arrangement and equipment efficiency checkup.

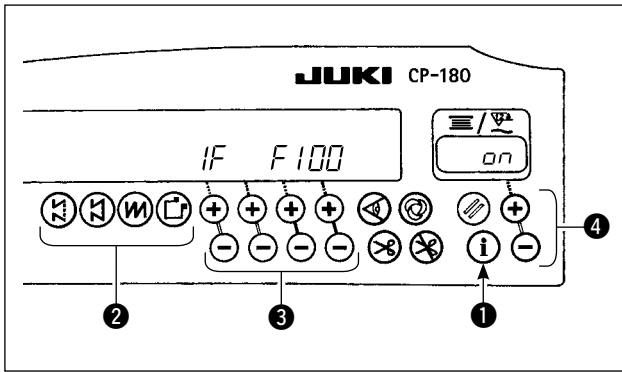

**< To display the production support modes >**

- 1) Keep switch ❶ held pressed (for one second) in the normal sewing state to call up the one-touch setting screen.
- 2) Then, press switch ❷ on the one-touch setting screen to display/hide the production support modes.
- 3) Select the mode to be displayed/hidden by pressing switch ❸.
- 4) ON/OFF of the display can be changed over by pressing switch ❹.
- 5) To return to the normal sewing state, press switch ❶.

**F100 to F500 modes have been factory-set to HIDE at the time of delivery.**

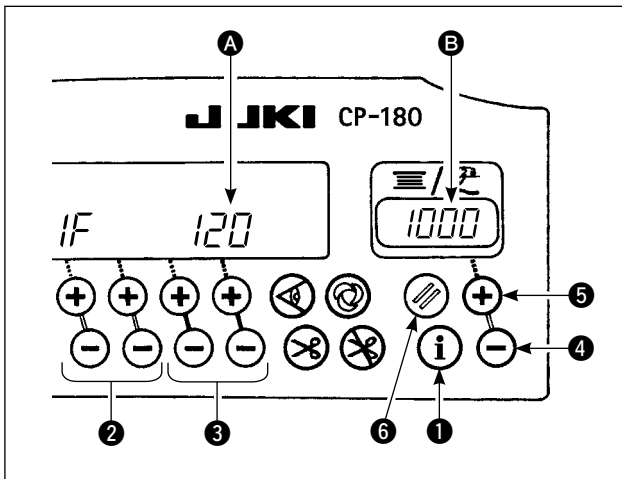

**< Basic operation of the production support modes >**

Sewing can be performed with the production support data displayed on the control panel.

- 1) When switch ❶ is pressed in the normal sewing state to enter the production support mode.
- 2) Production support function (F100 to F500) can be changed over by pressing switch ❷.
- 3) The data with an asterisk mark (\*1) in Table 1 "Display of modes" can be changed by pressing switch ❸. The data with an asterisk mark (\*2) can be changed by switch ❹ or switch ❺.
- 4) Refer to the Table 2 "Mode resetting operation" for the resetting procedure of data.
- 5) To return to the normal sewing state, press switch ❶.

Table 1: Display of modes

Mode name	Indicator A	Indicator B	Indicator B (when switch ❹ or switch ❺ is pressed)
Target No. of pcs. display mode (F100)	Actual No. of pcs. (Unit : Piece) (*1)	Target No. of pcs. (Unit : Piece) (*2)	-
Target/actual No. of pcs. difference display mode (F200)	Difference between target No. of pcs and actual No. of pcs (Unit : Piece) (*1)	Target pitch time (Unit : 100 msec) (*2)	-
Sewing machine availability rate display mode (F300)	$\sigma P-r$	Sewing machine availability rate in the previous sewing (Unit : %)	Display of average availability rate of sewing machine (Unit : %)
Pitch time display mode (F400)	$P, -r$	Pitch time in the previous sewing (Unit : 1 sec)	Display of average pitch time (Unit : 100 msec)
Average number of revolutions display mode (F500)	$RSPd$	Average number of revolutions in the previous sewing (Unit : sti/min)	Display of average number of revolutions (Unit : sti/min)

Table 2: Mode resetting operation

Mode name	Switch ⑥ (held pressed for 2 seconds)	Switch ⑥ (held pressed for 4 seconds)
Target No. of pcs. display mode (F100)	Resets the actual number of pieces. Resets the difference between target number of pieces and actual number of pieces.	-
Target/actual No. of pcs. difference display mode [F200]	Resets the actual number of pieces. Resets the difference between target number of pieces and actual number of pieces.	-
Sewing machine availability rate display mode (F300)	Resets average availability rate of sewing machine	Resets average availability rate of sewing machine. Resets average pitch time. Resets average number of revolutions of sewing machine.
Pitch time display mode (F400)	Resets average pitch time	Resets average availability rate of sewing machine. Resets average pitch time. Resets average number of revolutions of sewing machine.
Average number of revolutions display mode (F500)	Resets average number of revolutions of sewing machine	Resets average availability rate of sewing machine. Resets average pitch time. Resets average number of revolutions of sewing machine.

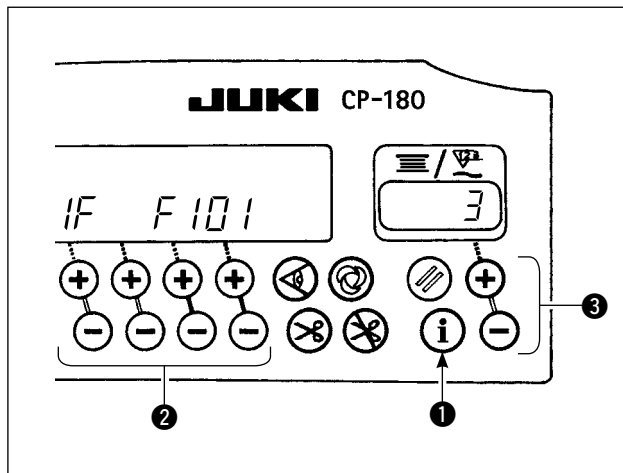

**< Detailed setting of production volume management function (F101, F102) >**

- When switch ① is held pressed (for three seconds) under the target No. of pcs. display mode (F100) or the target/actual No. of pcs. difference display mode (F200), the detailed setting of the production volume management function can be carried out.
- The setting state of the number of times of thread trimming (F101) and that of the target achievement buzzer (F102) can be changed over by pressing switch ②.
- The number of times of thread trimming for sewing one piece of garment can be set by pressing switch ③ in the setting state of the number of times of thread trimming (F101).
- It is possible to set whether the buzzer sounds or not when the actual number of pieces has reached the target volume by pressing switch ③ in the setting state of the target achievement buzzer.

## 10. HOW TO USE THE BOBBIN THREAD COUNTER

The machine detects the number of stitches. The preset value on the bobbin thread counter is subtracted in accordance with the number of stitches detected. (Subtraction is made according to the setting of function setting No. 7, bobbin thread count down unit.) When the value on the counter becomes a minus value as "1 → 0 → -1", the buzzer peeps three times to warn the operator that the time to change the bobbin thread has come.

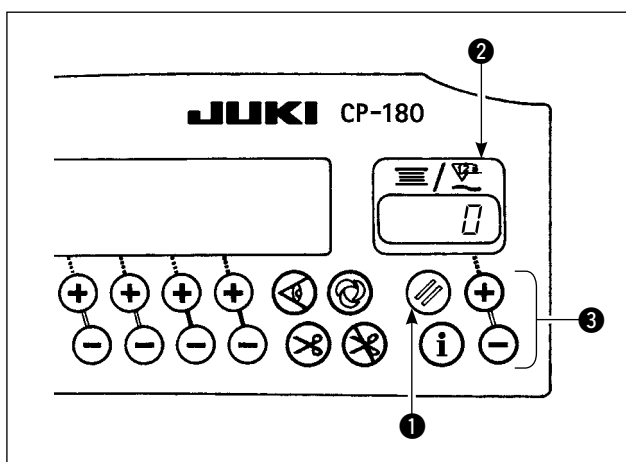

- 1) Press bobbin thread counter reset switch **1** to return the value indicated on bobbin thread counter **2** to the initial value (it has been factory-set to "0" at the time of delivery).



**The bobbin thread counter cannot be reset during sewing. In this case, make the thread trimmer actuate once.**

- 2) Specify an initial value using bobbin thread amount setting switch **3**. When keeping pressing the switch, the change-over speed is increased.

### < Initial value on the bobbin thread counter for reference >

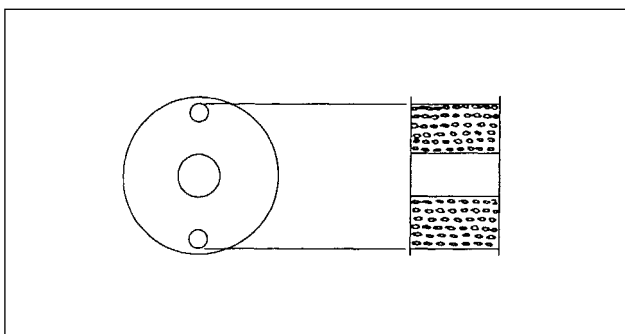

The table below gives the initial setting values for reference when the bobbin is wound with thread to the extent that the pinhole in the outside of the bobbin case is reached as shown in the figure given above.

Thread used	Length of thread wound round the bobbin	Value on bobbin thread counter
Polyester spun thread #50	36m	1200 (stitch length : 3 mm)
Cotton thread #50	31m	1000 (stitch length : 3 mm)

Thread tension rate 100 %

- ※ Actually, the bobbin thread counter is affected by the material thickness and the sewing speed. So, adjust the initial value of the bobbin thread counter in accordance with the operating conditions.

- 3) Once the initial value is specified properly, start the sewing machine.
- 4) When a minus value is shown on the counter and the buzzer peeps three times, replace the bobbin thread.
- 5) After the bobbin thread has been properly replaced, press bobbin thread counter reset switch **1** to return the value on the bobbin thread counter to the initial value. Now, re-start the sewing machine.
- 6) If the remaining amount of bobbin thread is excessive or the bobbin thread runs out before the bobbin thread counter indicates a minus value, adjust the initial value appropriately using the "+" or "-" switch of bobbin thread adjustment switch **3**.

If the remaining amount of bobbin thread is excessive ... Increase the initial value using the "+" switch.

If the remaining amount of bobbin thread is insufficient ... Decrease the initial value using the "-" switch.



1. Uneven performance may occur in accordance with the winding way of thread or the thickness of materials and it is necessary to set the thread trimming amount with some surplus.
2. If the bobbin thread counter is used in combination with the bobbin thread remaining amount detecting device, the bobbin thread counter indicates the number of detections of the bobbin thread remaining amount detecting device. So, be sure to use the device after carefully reading the Instruction Manual for the bobbin thread remaining amount detecting device.

## 11. HOW TO USE THE THREAD TRIMMING COUNTER

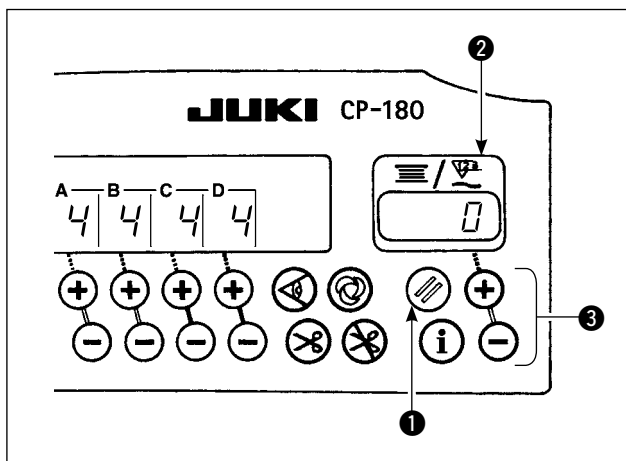

Bobbin thread counter indication can be changed over to thread trimming counter (simplified sewing counter) indication by the operation below.

- 1) Function setting No. 6 Turn OFF the setting of bobbin thread counter function. .  
( 0 : off / 1 : on )
- 2) Function setting No. 14 Turn ON the setting of sewing counter function.  
( 0 : off / 1 : on )
- 3) From turning ON the power next, the counter indication works as the thread trimming counter. Every time thread trimming is performed, the counter indication is upped.



After selecting each item, be sure to perform updating of the function setting No. When turning OFF the power without performing updating, the set contents are not changed. For the updating procedure, refer to "18. FUNCTION SETTING SWITCH" p.15.

- 4) When reset switch ① is pressed, the contents of indication ② will be reset to " 0 ".
- 5) When modifying the count value, increase/decrease the value with setting switch ③.

## 12. NEEDLE UP/DOWN COMPENSATION SWITCH

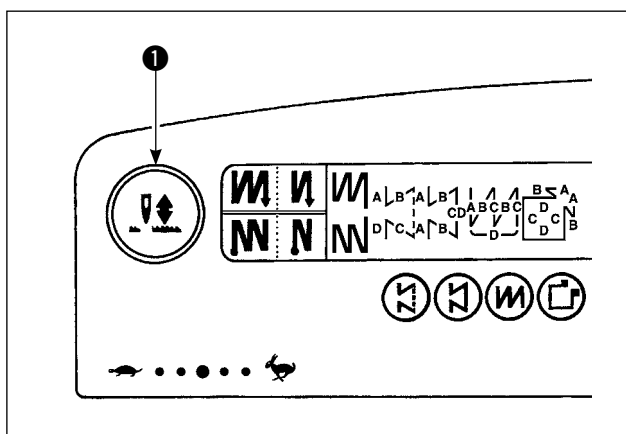

Every time needle up/down compensation switch ① is pressed, the needle goes up when it is in its lowest position or comes down when it is in its highest position. This compensates the stitch by a half of the predetermined stitch length. However, note that the machine does not run continuously at a low speed even if you keep the switch held pressed. Also, note that the needle up/down compensation switch is inoperative after turning the handwheel by hand. Sewing of needle up/down compensation operation does not make the thread trimming operation operative.

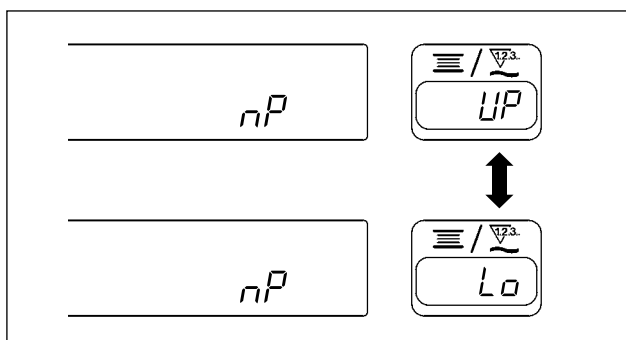

Whenever pressing the needle up/down compensation switch ① and turning ON the power to the machine, the stop position when the pedal is in its neutral position can be changed over.

Also, the specified state at this time can be confirmed at the panel.  
(The contents shown there will be reflected when turning ON the power after next time.)

## 13. KEY LOCK FUNCTION

In order to prevent the specified data on the number of stitches or the processes (A, B, C and D) to be changed by mistake, the setting switch can be locked. (Even with the setting keys locked, the pattern to be sewn and the value on the bobbin thread counter can be changed.)

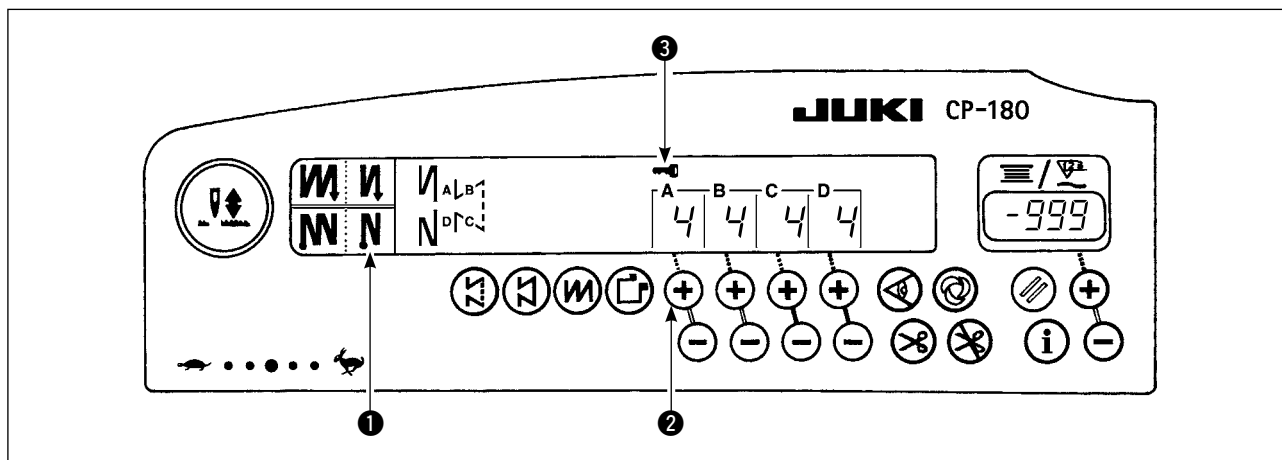

- 1) After the completion of the setting of data on the number of stitches, etc., turn OFF the power to the machine once.
  - 2) Turn ON the power switch while simultaneously pressing automatic reverse stitching (for end) switch ❶ and the "+" switch of number of stitches setting switch ❷ for process A with fingers.
  - 3) Key mark ❸ is shown on the control panel. This completes the locking of keys.  
(If the key mark is not shown on the control panel, carry out the aforementioned steps 1) through 3) again.)
- \* To release the keys from the locked state, perform again the steps 1) and 2).  
(Once the key mark goes out, the keys are released from the locked state.)

## 14. ON/OFF SWITCH ❸ OF THE MATERIAL EDGE SENSOR

- When the material edge sensor, which is optionally available, is connected to the control panel, the ON/OFF switch of the material edge sensor becomes effective.
- If the material edge sensor is specified, the sewing machine will automatically stop running or perform thread trimming when the sensor detects the material edge.



If the material edge sensor is used in combination with the control panel, carefully read the Instruction Manual for the material edge sensor beforehand.

## 15. AUTOMATIC THREAD TRIMMING SWITCH ❹



- This switch is used to automatically actuate the thread trimmer in a process where the sewing machine automatically stops or when the material edge sensor is used.  
(If the automatic reverse stitching (for end) is specified, the thread trimmer will actuate after the sewing machine completes the automatic reverse stitching (for end).)

## 16. ONE-SHOT AUTOMATIC STITCHING SWITCH ❺

- This switch is used, in the constant-dimension stitching mode, rectangular stitching mode, or in the process where the material edge sensor is specified, to make the sewing machine automatically perform sewing at the specified speed until the end of the process is reached only by driving the sewing machine mode.



## 17. THREAD TRIMMING PROHIBITION SWITCH

- This switch is used to temporarily make the thread trimming function inoperative. The other performance of sewing machine is not affected by this switch. (If the automatic reverse stitching (for end) is specified, the sewing machine will perform the automatic reverse stitching at the end of sewing.)
- If the automatic thread trimming switch  and the thread trimming prohibition switch  are both specified, the machine will not perform thread trimming but stop with its needle up.

## 18. FUNCTION SETTING SWITCH

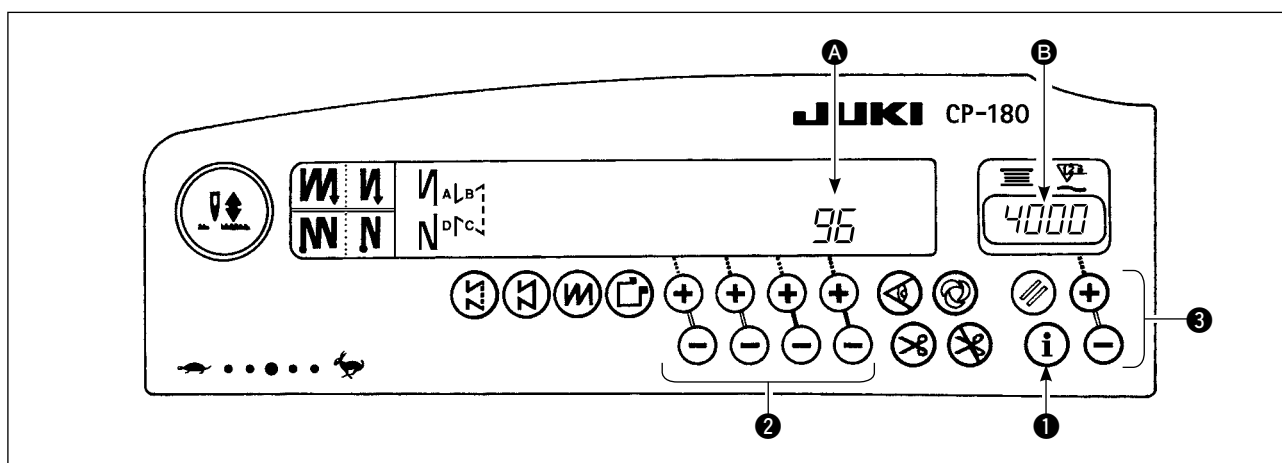

- 1) Pressing function setting switch ①, turn ON the power to the machine.
- 2) The indication on the control panel is changed over to the function setting indication mode. Function setting No. is shown at section A and the set value is shown at section B of counter indication section.  
\* The contents to be shown will be different according to the contents that were set in the last time.
- 3) Function setting No. can be changed over by operating switch ②.
- 4) Function set value (setting state in case of on/off) can be changed over by operating switch ③.
- 5) After completion of setting, by operating switch ② the changed contents are stored in memory and reflected from the next time.
- 6) For the details of the contents of function setting, refer to the Instruction Manual supplied with the control box.



Refer to SC-920 instruction manual for the function setting list, details of the function setting and the optional input/output connector.

## 19. OPTIONAL INPUT/OUTPUT SETTINGS

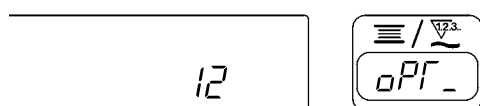
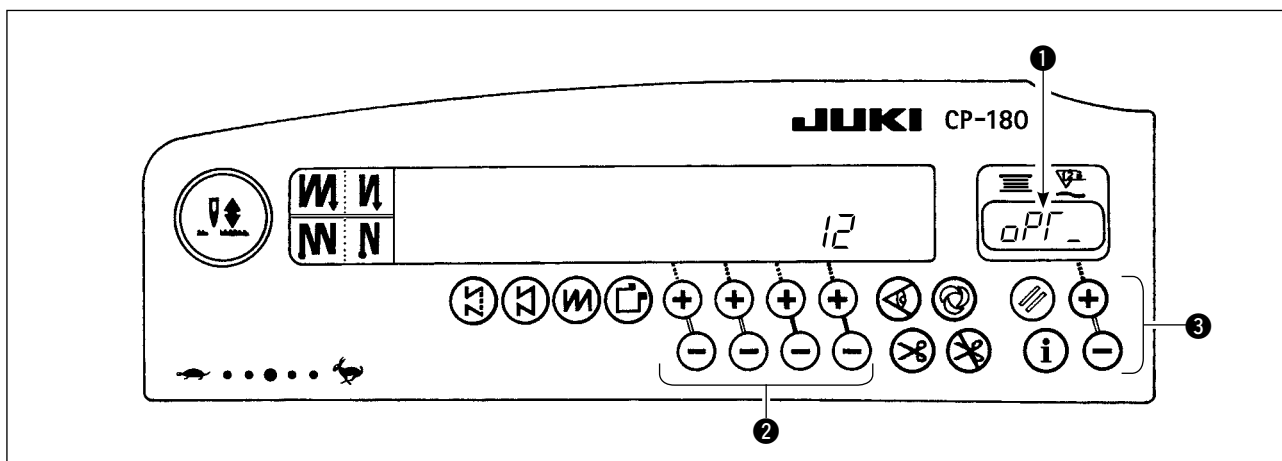

1) Select function number 12.

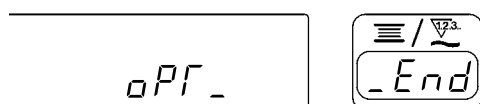

2) Select the items of "End", "in" and "out" using switch ③.

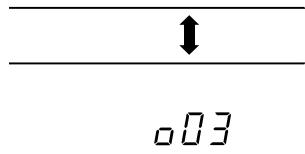
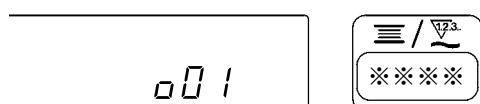
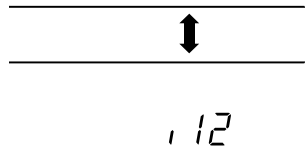
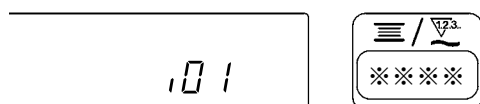
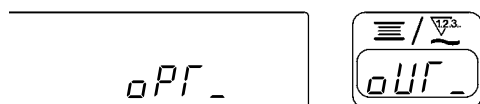
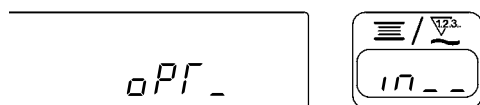

### [When "in" is selected]

Specify the displayed number of the input function setting connector by means of switch ②. Then, specify the connector pin function corresponding to the displayed number by means of switch ③.

Function code and abbreviation are displayed alternately in ①.

### [When "out" is selected.]

Specify the displayed number of the output function setting connector by means of switch ②. Then, specify the connector pin function corresponding to the displayed number by means of switch ③.

Function code and abbreviation are displayed alternately in ①.

\* Refer to the Instruction Manual for the control box for the displayed numbers of the function setting connectors and the function codes.

Example) The thread trimming function is assigned to the displayed number "101" of the input function setting connector.

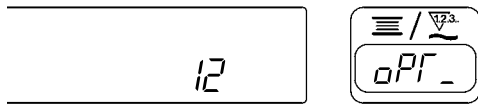

1) Select function number 12 according to the function setting method.

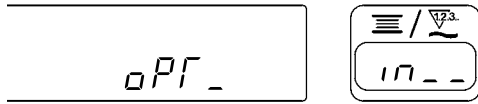

2) Select the item of "in" by switch ③.

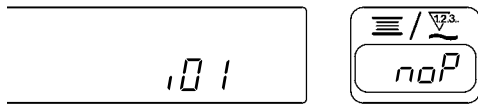

3) Select the displayed number "101" by means of switch ②.

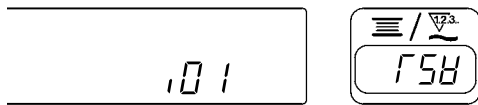

4) Select "FSH" thread trimming function by switch ③.

The lamps will light up alternately. ↑

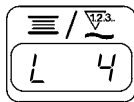

5) Fix "FSH" thread trimming function by switch ②.



6) Set activation of signal by switch ③. If the thread trimming is performed by "Low" signal, set the display to "L", and if the thread trimming is performed by "High" signal, set the display to "H".

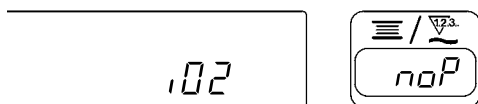
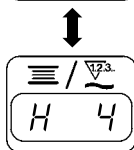

7) The above function is fixed by switch ②.



8) The option input is ended by switch ②.

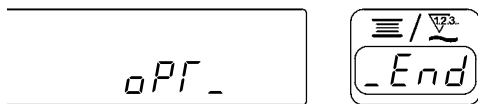

9) Select the item of "End" by switch ③, and return to the function setting mode.

## 20. AUTOMATIC COMPENSATION OF NEUTRAL POINT OF THE PEDAL SENSOR

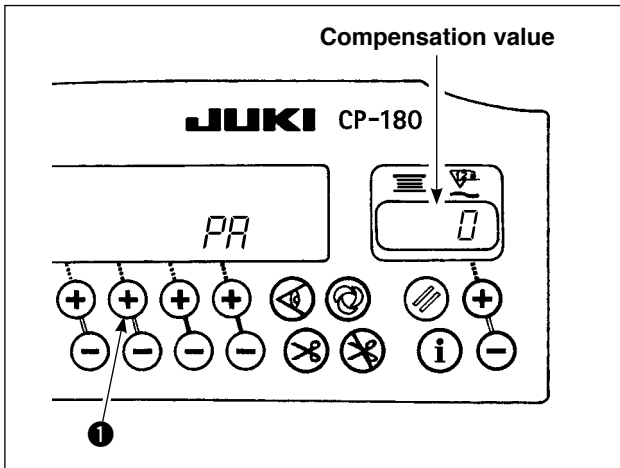

Whenever the pedal sensor, spring, etc. are replaced, be sure to perform following operation.

- 1) Pressing the switch ❶, turn ON the power switch.
- 2) Compensation value is displayed in the indicator as illustrated.

1. At this time, the pedal sensor does not work properly if the pedal is depressed. Do not place the foot or any object on the pedal. Warning sound "blip" and the compensation value is not displayed.

2. When any thing other than number is displayed in the indicator, refer to the Engineer's Manual.

- 3) Turn OFF the power switch, and turn ON the power switch again to return to the normal mode.

## 21. SETTING OF THE AUTO LIFTER FUNCTION



### WARNING :

When the solenoid is used with the air drive setting, the solenoid may be burned out. So, do not mistake the setting.

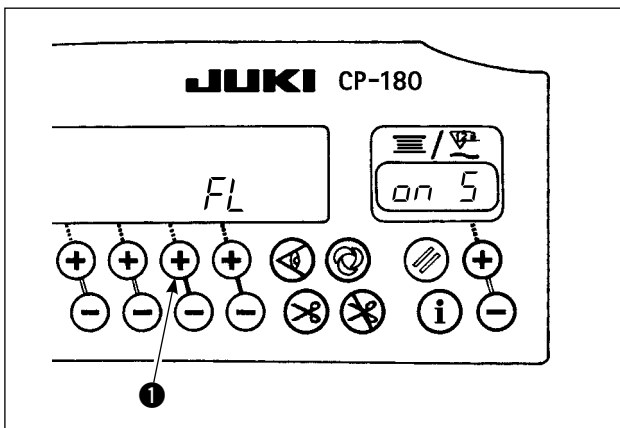

When the auto-lifter device (AK) is attached, this function makes the function of auto-lifter work.

- 1) Turn ON the power switch while pressing switch ❶.
- 2) LED display is turned to "FL" "on" with "blip", and the function of auto-lifter becomes effective.
- 3) Turn OFF the power switch and turn ON the power switch again. The machine returns to the normal motion.
- 4) Repeat the operation 1) to 3), and LED display is turned to "FL" "off". Then, the function of auto-lifter does not work.

"FL" "on" : Auto-lifter device becomes effective. Selection of the auto-lifter device of solenoid drive (+33V) or of air drive (+24V) can be performed with switch ❷.

(Changeover is performed to drive power +33V or +24V of CN37.)

"FL" "on 5" : Solenoid drive display (+33V)

"FL" "on R" : Air drive display (+24V)

"FL" "off" : Auto-lifter function does not work. (Standard at the time of delivery)

(Similarly, the presser foot is not automatically lifted when programmed stitching is completed.)

1. To perform re-turning ON of the power, be sure to perform after the time of one second or more has passed. (If ON/OFF operation of the power is performed quickly, setting may be not changed over well.)

2. Auto-lifter is not actuated unless this function is properly selected.

3. When "FL" "on" is selected without installing the auto-lifter device, starting is momentarily delayed at the start of sewing. In addition, be sure to select "FL" "off" when the auto-lifter is not installed since the touch-back switch may not work.

## 22. INITIALIZATION OF THE SETTING DATA

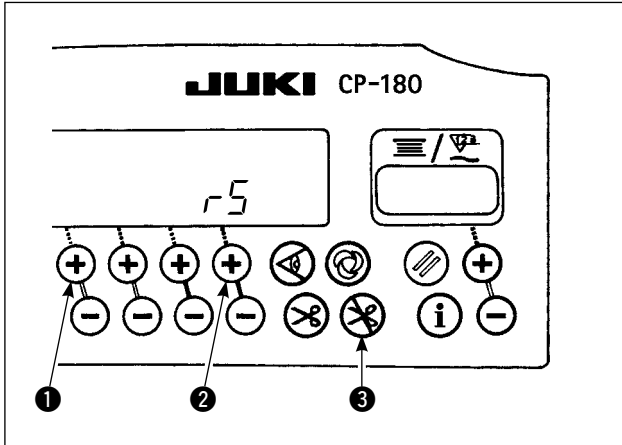

All contents of function setting can be returned to the standard set values.

- 1) Pressing all switches ❶, ❷ and ❸, turn ON the power switch.
- 2) "r5" is displayed on indicator with a "blip" to start initialization.
- 3) The buzzer sounds after approximately one second (single sound three times, "blip", "blip", and "blip"), and the setting data returns to the standard setting value.



**Do not turn OFF the power on the way of initializing operation. Program of the main unit may be broken.**

- 4) Turn OFF the power switch and turn ON the power switch again to return to the normal mode.

1. When you carry out the aforementioned operation, the neutral position correction value for the pedal sensor is also initialized. It is therefore necessary to carry out automatic correction of the pedal sensor neutral position before using the sewing machine.

(Refer "20. AUTOMATIC COMPENSATION OF NEUTRAL POINT OF THE PEDAL SENSOR" p.18.)



2. When you carry out the aforementioned operation, the machine-head adjustment values are also initialized. It is therefore necessary to carry out adjustment of the machine head before using the sewing machine.

(Refer "5. ADJUSTING THE MACHINE HEAD" p.3.)

3. Even when this operation is performed, the sewing data set by the operation panel cannot be initialized.

## 23. CHECKING PROCEDURE OF THE ERROR CODE

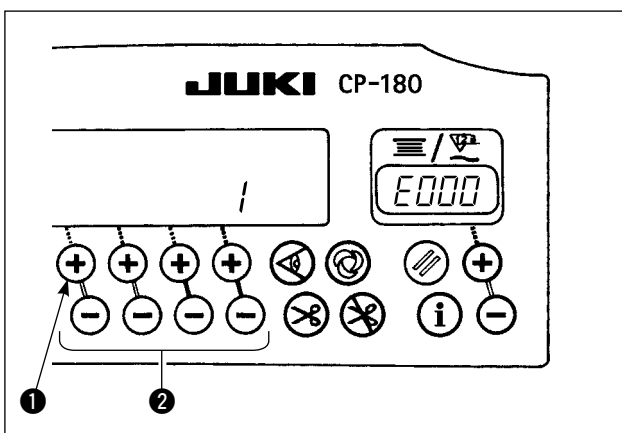

- 1) Turn ON the power switch with switch ❶ held pressed.
- 2) The latest error number is displayed on indicator with blip.
- 3) Contents of previous errors can be checked by pressing switch ❷.

(When the procedure has reached the end, two alarm sounds in single tone will be heard, "blip" "blip".)